

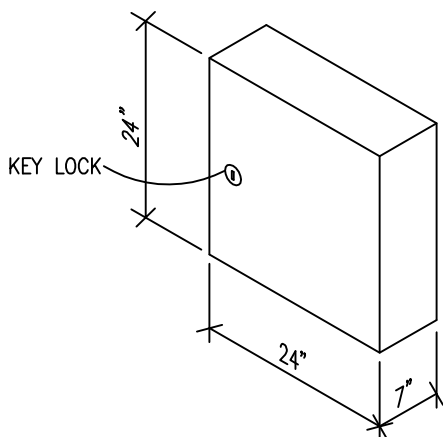

DISCONNECT
BY ICOC

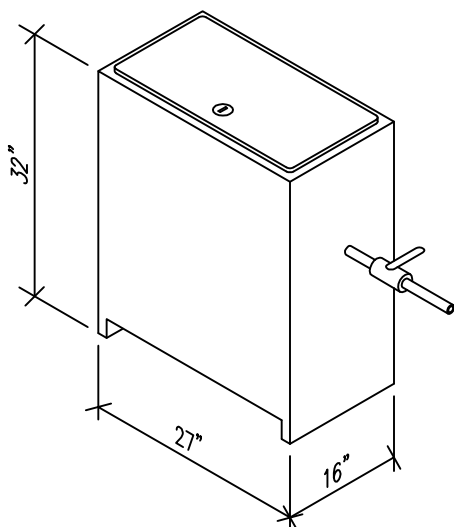

CONTROL PANEL
BY ICOC



PUMP UNIT
BY ICOC

ELEVATOR MACHINE ROOM
MUST HAVE INSTALLED (BY OTHERS):

- 1) 240 VOLT, 30 AMP POWER CIRCUIT (4 WIRE SYSTEM, #10 WIRE),
- 2) LIGHT SWITCH; ON WALL WITHIN 12" OF LATCHSIDE OF DOOR,
- 3) CEILING LIGHT WITH GUARD,
- 4) TELEPHONE JACK,
- 5) SEPARATE 120 VOLT POWER FOR ELEVATOR CAR LIGHT,
- 6) 120 VOLT SERVICE RECEPTACLE,
- 7) SELF-LOCKING, SELF-CLOSING DOOR.

CONTROL PANELS
UL #BB798204/E155780

PUMP UNIT:

240 VOLT AC, SINGLE PHASE MOTOR.
CMR 750: 3.0 HP (14 FLA, 56 LRA)
CMR 450: 2.0 HP

SUBMERGED PUMP: CMR 750 - 5.5 GPM
CMR 450 - 3.5 GPM

WORKING PRESSURE: 595 PSI

COIL VOLTAGE, 120 VOLTS.



INCLINATOR CO. of CA.
8116-A BYRON ROAD
WHITTIER, CA. 90606
(562) 696-6867
(800) 201-1212

CEMCO CMR 750 & 450
MACHINE ROOM
EQUIPMENT & SPECS

EQUIPMENT

SCALE: NONE
FILE: IC-EQUIP.DWG
DATE: 22 JUN 2005